

# LTX Technical Data

## Electric Tractor and Transporter

---

LTX 70

---

LTX-T 08

---



# LTX Tractor

## Intelligent pulling

This specification sheet, which conforms to VDI guideline 2198, provides the technical values for the standard equipment only. Different tyres, other masts, the use of accessories, etc. may result in other values..



Distinguishing marks	1.1	Manufacturer			STILL	STILL	
	1.2	Manufacturer's type designation			<b>LTX 70</b>	<b>LTX-T 08</b>	
	1.3	Drive			Electro	Electro	
	1.4	Operation			Seated	Seated	
	1.5	Nominal load capacity/load	Q	t	0.15	0.80	
Weights	1.7	Rated drawbar pull	F	N	1400	1400	
	1.9	Wheel base	y	mm	1190	1795	
	2.1	Weight incl. battery with/without cabin		kg	1260/1515	1215 1470	
Weights	2.2	Axle weight with front load/rear load	laden	kg	662/853	580/1435 740/1530	
	2.3	Axle loadings front/rear	unladen	kg	550/710	580/635 740/730	
Tyres   chassis	3.1	Tyres			Superelastic/ pneumatic/Air	Superelastic/ pneumatic/Air	
	3.2	Tyre size	front		4.00-8/6PR	4.00-8	
	3.3	Tyre size	rear		4.00-8/6PR	4.00-8	
	3.5	Wheels - number (x = drive wheel)	front/rear		1/2x	1/2x	
	3.7	Track width	rear	b <sub>11</sub>	mm	860	860
Basic dimensions	4.7	Height to top of overhead guard (cabin)		h <sub>6</sub>	mm	2070	2070
	4.8	Seat height relative to SIP		h <sub>7</sub>	mm	1020	1020
	4.12	Coupling height a, b, c		h <sub>10</sub>	mm	285/340/395	285/340/395
	4.13	Loading height	unladen	h <sub>11</sub>	mm	645	680
	4.16	Length of loading platform		l <sub>3</sub>	mm	350	1595 1275
	4.17	Length of overhang		l <sub>5</sub>	mm	350	840
	4.18	Width of loading platform		b <sub>9</sub>	mm	900	900
	4.19	Overall length		l <sub>1</sub>	mm	1830	2955
	4.21	Overall width		b <sub>1</sub>	mm	998	998
	4.32	Ground clearance at centre of wheelbase		m <sub>2</sub>	mm	135	135
	4.34	Aisle width at given load dimensions		A <sub>st</sub>	mm	2765	3520
	4.35	Outer turning radius	front	W <sub>af</sub>	mm	1650	2230
	4.35.1	Turning radius	rear	W <sub>ar</sub>	mm	1115	1290
4.36	Inner turning radius		b <sub>13</sub>	mm	600	600	
Performance data	5.1	Speed	laden/unladen	km/h	11/19	11/20	
	5.5	Drawbar pull	laden/unladen	N	See diagram	See diagram	
	5.6	Max. drawbar pull	laden/unladen	N	See diagram	See diagram	
	5.7	Gradeability laden	laden/unladen	%	See diagram	See diagram	
	5.8	Max. gradeability	laden/unladen	%	See diagram	See diagram	
5.10	Brakes				Hydraulic/electric	Hydraulic/electric	
Electric engine	6.1	Drive motor, output S2 60 min		kW	4.5	4.5	
	6.3	Battery equipment to DIN 4353/35/36 A, B, C			DIN 43531 A	DIN 43531 A	
	6.4	Battery capacity K <sub>5</sub>		V/Ah	48 V 3PzS 345/375	48 V 3PzS 240	
	6.5	Battery weight		kg	560	394	
10.7	Sound pressure level L <sub>PAZ</sub> (driver's seat)		dB (A)	60	60		
Misc.	10.8	Trailer coupling, type/DIN			3-steps-coupling	3-steps-coupling	
	10.9	Height step	min./max.	mm	350/370	350/370	
	Battery change				Lateral	Lateral	

LTX Tractor  
 Technical Drawings

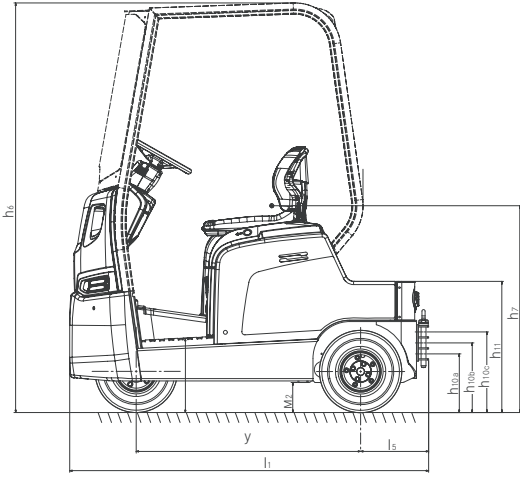

LTX 70 Side view

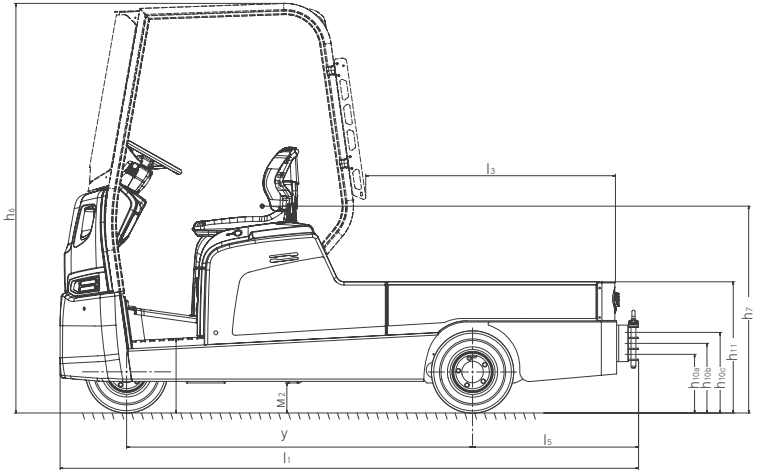

LTX-T 08 Side view

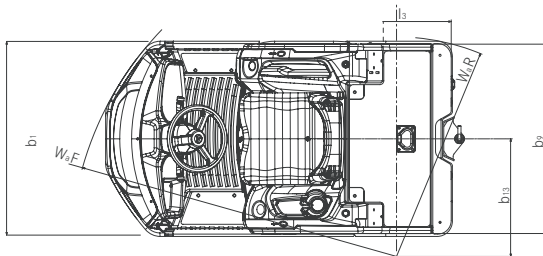

LTX 70 Top view

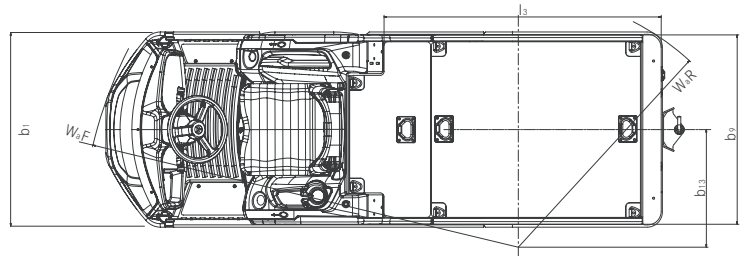

LTX-T 08 Top view

Power diagram LTX 70

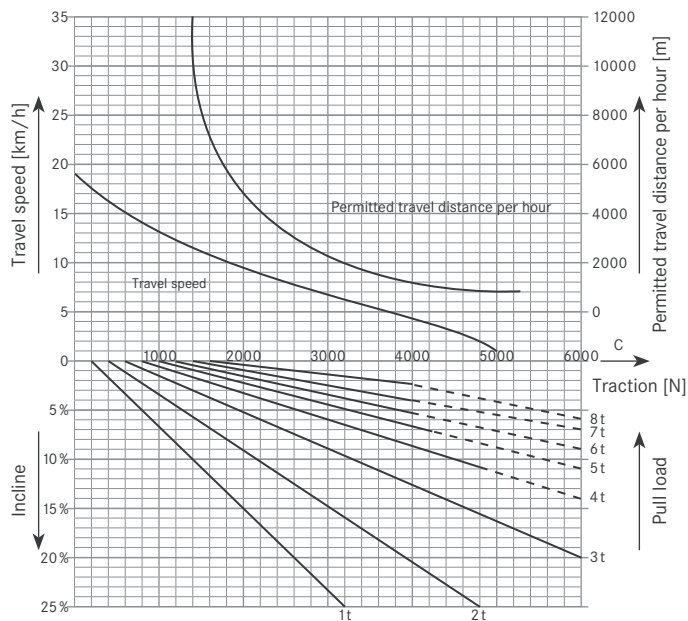

Power diagram LTX-T 08

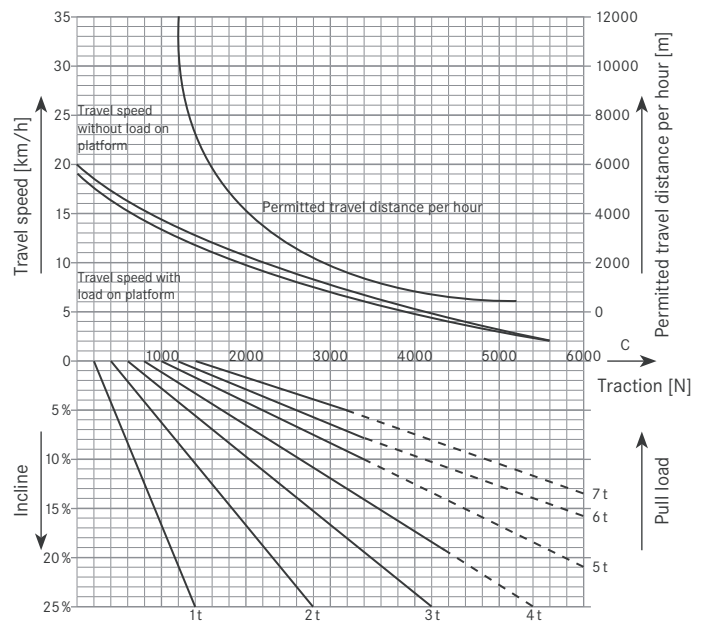

With combinations of pull load and incline, shown by the solid line, a further approach to the incline can be made after stopping. The permitted travel distance per hour is the total distance including the return journey and descents. It is recommended to use trailers with brakes if the trailer weight is more than 2.5 t and for all trailer loads if there is travel on inclines/gradients.

LTX Tractor  
Detailed Photos



Lateral battery change



STILL Ramp Indicator



Pedestrian function



Large footwell



Step



Adjustable steering column



LED daytime driving lights



## LTX Tractor Intelligent pulling

---

Low access step and spacious footwell

LED daytime driving lights – low energy consumption,  
high safety level, long durability

Pedestrian operation provides efficient production supply



Three letters stand for the next stage of evolution in electric tractors and transport vehicles: LTX. This forward-looking forklift truck pulls up to eight tonnes quickly and reliably to wherever you want – whether indoors or outdoors. The automatic parking brake ensures safe starting on ramps and easy dismounting: It is activated as soon as the vehicle is stationary. The STILL Ramp Indicator also informs the driver at all times of the current incline or gradient. Achieving optimal forklift truck utilisation has never been easier. Even frequent entry and exit over short distances is a thing of the past with the LTX, as with pedestrian operation the vehicle follows the operator at every turn.

It is not just the low access step that makes it comfortable to take your seat in the truck: The driver's seat that is also used in the forklift sector impresses with its excellent springing and cushioning, while the spacious footwell also provides sufficient space for the largest work shoes. The durable and environmentally friendly LED daytime driving lights ensure the vehicle is visible at all times – a significant plus for safety at work. The multifunctional use, whether in the production supply, as tigger train, in the facility management or in the transport of luggage at airports: The future of more efficient horizontal transports has begun.

## Extensive equipment

---

### Power

---

- High handling rate: pulls and transports loads of up to 8 tonnes
- Fast transport of goods thanks to top speed of up to 20 km/h and high gradeability
- Optimal forklift truck utilisation: Gradient display informs you at a glance of the current incline and gradient situation

### Precision

---

- Couple trailer quickly and safely with clear view of the trailer coupling
- Precision at the touch of a button: Reversing device enables you to drive the tractor safely and precisely up to the trailer
- Sensitive acceleration and steering guarantee that goods are transported safely and smoothly

### Ergonomics

---

- Pedestrian operation: Simply touching a button saves frequent exits and entries on short stretches
- Comfortable seats: STILL has designed modern sprung and cushioned driver's seats for its forklift trucks to provide high levels of comfort
- Easy access thanks to low step
- Simple, fast, stress-free: Lateral battery change gives renewed energy in just a few moments

- Always hands-free: generous storage facilities in the truck, e.g. for documents, drinking bottles and mobile devices
- Easily accessible load bed height of 680 mm (transporter) and 645 mm (tractor)

### Safety

---

- Optimum safety through combination of three braking systems: electric brake, hydraulic brake and automatic parking brake
- Be seen: LED daytime driving lights make the vehicle clearly visible to other drivers
- No unintended rolling away: The automatic parking brake is activated as soon as the truck is stationary
- Optimal driver safety: STILL has produced a stable forklift truck cab with optional lap belt for the driver's protection

### Environmental responsibility

---

- Long-lasting and energy-saving LED lamps
- Low wear and long service intervals of 1,000 operating hours
- High durability of the tractor battery through easy maintenance: Battery's acid level is monitored and shown in the display
- Blue-Q efficiency mode saves up to 10 per cent energy at the press of a button with no loss of performance
- Over 95 percent of all installed materials are recyclable

# LTX Tractor Equipment Variants



	LTX 70	LTX-T 08	
Driver's cab	Sprung and cushioned chassis	●	●
	Integrated storage facilities, drink holder	●	●
	LCD display to show active operating statuses	●	●
	Adjustable steering column	●	●
	12 V vehicle socket	●	●
	Sprung driver's seat, adjustable to truck length and weight	●	●
	Sprung driver's seat, adjustable to truck length and weight, with seat heating	○	○
	Lap belt for driver's seat	○	○
	Removable clipboard	○	○
	Driver's cab, height 2,070 mm	○	○
	Weather protection, height 2,070 mm	○	○
	Load protection grid to secure the load in the direction of travel	○	●
	Ventilator in the cab	○	○
	Display in km/h	●	●
	Display in mph	○	○
Drives	Maintenance-free drive motor	●	●
	Fully enclosed drive motor	●	●
Brake	Integral current and temperature sensors for function monitoring	●	●
	Regenerative braking system	●	●
	Energy recovery when braking	●	●
	Hydraulic operating brake	●	●
Safety and performance	Automatic parking brake	●	●
	FleetManager: Access authorisation	○	○
	FleetManager: Shock detection	○	○
	FleetManager: Reports	○	○
	PIN code access, keyless, with rotary control	○	○
	Lighting in accordance with German Road Traffic Licensing Regulation	○	○
	Display of ramp angle in % for travel on inclines and gradients STILL Ramp Indicator	●	●
	Incline start assistant	●	●
	Working lights	○	○
	Lighting unit set high at rear	○	○
	Steering angle-dependant speed control	○	○
	Speed selector switch to limit the max. forward speed preset to 20/12 km/h	●	●
Reversing device to rear right and left	○	○	
Lashing eyes on the platform	○	●	
Tarpaulin and roof arch construction	—	○	
Battery system	Battery changing with changing frame and pallet truck	●	●
	Lateral battery changing with roller track	○	○
	Battery bridge for lateral battery removal and replacement	○	○
	Built-in charger	○	○
	Additional exterior battery socket	○	○
Additional equipment	Protective skirting at front	○	○
	Trailer coupling with 3 levels at rear	●	●
	Electrically unlocked trailer coupling at rear	○	○
	Trailer coupling at front	○	○
	Data terminal and printer for preparation	○	○
	Device holder for the installation of raised lighting units	○	○
	Fastening clamp for terminal, clipboard, mirror and boarding aid	○	○
	Hydraulic supply to operate hydraulically driven tugging train trailer	○	○
Pedestrian operation for easy order picking	○	○	

● Standard ○ Optional — Not available

# STILL



STILL Materials Handling Ltd  
Aston Way  
Leyland Preston  
PR26 7UX  
Tel.: +44 (0)845 603 6827  
Fax: +44 (0)1772 454668

STILL Materials Handling Ltd  
19 Hennock Road  
Marsh Barton Trading Estate  
Exeter  
EX2 8RU  
Tel.: +44 (0)1392 435151  
Fax: +44 (0)1392 824328  
info@still.co.uk  
For further information please visit:  
[www.still.co.uk](http://www.still.co.uk)



STILL is certified in the following areas: Quality management, occupational safety, environmental protection and energy management.



first in intralogistics